



**White Paper**

**All You Need To Know About  
Power over Ethernet (PoE)  
and the IEEE 802.3af Standard**

Galit Mendelson  
Senior Product Manager

June 2004  
PowerDsine Proprietary Information





---

## Table of Contents

<b>1</b>	<b>Introduction</b> .....	<b>5</b>
	What is Power over Ethernet? .....	5
	What is the IEEE 802.3af Standard? .....	5
	Benefits of PoE .....	5
	Paper Goals .....	6
<b>2</b>	<b>PoE Technology</b> .....	<b>7</b>
	Technological PoE Challenges.....	7
	IEEE 802.3af Standard Status .....	8
	MDI Settings .....	8
	PoE System Architecture .....	10
	What are PSE and PD? .....	10
	Basic PSE.....	11
	Basic PD .....	12
<b>3</b>	<b>The PoE Provision Process</b> .....	<b>14</b>
	Line Detection .....	15
	Classification .....	16
	Start-up .....	16
	Operation .....	17
	Power Disconnection Scenarios .....	18
	Power Management.....	19
<b>4</b>	<b>PoE Solutions</b> .....	<b>20</b>
	Midspan Solutions .....	20
	Integrated Solutions.....	21
	Compatible PDs .....	21
	About PowerDsine .....	21

## List of Tables

Table 1 - RJ-45 PoE Pinout.....	8
Table 2 - 802.3af basic requirements from PD .....	13
Table 3 - PD Classification values.....	16

## Table of Figures

Figure 1 - Typical PoE installation ..... 6

Figure 2 – PoE feeding using Alternative A (Data/Signal pairs) ..... 8

Figure 3 – PoE feeding using Alternative B (Spare pairs) ..... 9

Figure 4 – PSE and PD interconnection ..... 10

Figure 5 – Basic PSE Front-End (single port)..... 11

Figure 6 - Endspan PSE configuration ..... 11

Figure 7 – Midspan PSE configuration ..... 12

Figure 8 – Basic PD Front-End ..... 13

Figure 9 - PoE process cycle..... 14

Figure 10 – PSE's signal during PoE process ..... 15

Figure 11 – Resistive signature thresholds ..... 15

Figure 12 - PoE Provision Startup..... 16

Figure 13 - Normal Operation..... 17

Figure 14 - Power Overload Handling (Tcut = 50 to 75 ms) ..... 17

Figure 15 - Power Disconnect Timeout (T = 300 to 400 ms) ..... 18

Figure 16 - DC Modulation ..... 18

Figure 17 - AC Disconnect Levels ..... 19

Figure 18 – PowerDsine's 6000 series of PoE Hubs ..... 20

Figure 19 - PowerDsine's 3000 series of PoE Hubs..... 20

Figure 20 - PowerDsine's PD64012 PoE IC (left) and PD67000 PoE DIMM Module (right) ..... 21

Figure 21 – Avaya AP-5 WLAN AP, Cisco 7970 IP Phone, Sony SNC-Z20N Net Camera ..... 21

## Revision History

Revision	Release Date	Details
1.0	June 14, 2004	First release

---

## 1 Introduction

### What is Power over Ethernet?

Have you, or your customers, ever attempted to install networked devices on a corporate network, only to find out that it would either be too cumbersome, or too costly, to add a power outlet at what seemed like the perfect location? Ever needed to install a wireless access point where electric power infrastructure just couldn't reach? If you did, then you too have encountered the need for Power over Ethernet.

Power over Ethernet (also known as PoE) is a revolutionary technology that allows IP telephones, wireless LAN Access Points, Security network cameras and other IP-based terminals to receive power, in parallel to data, over the existing CAT-5 Ethernet infrastructure without the need to make any modifications in it. PoE integrates data and power on the same wires, it keeps the structured cabling safe and does not interfere with concurrent network operation.

PoE delivers 48v of DC power over unshielded twisted-pair wiring for terminals consuming less than 13 watts of power.

### What is the IEEE 802.3af Standard?

The IEEE 802.3af, also called Data Terminal Equipment (DTE) Power via Media Dependent Interface (MDI), is the first international standard to define the transmission of power over Ethernet infrastructure. The standard was ratified in June 2003.

### Benefits of PoE

- **Cost Saving** - PoE saves time and money by avoiding the need for separate installation of Data and Power infrastructures. Such cost can extend to few hundreds dollars per Ethernet port, when an electrical technician is involved.
- **Simplicity** - Power is fully integrated with Ethernet infrastructure, so access to rough places for power deployment, such as ceilings, becomes simpler.
- **Mobility** - Powered devices (PDs) can be easily moved without need for AC outlets, minimizing business disruption. Wherever there is an Ethernet connection, a PD can be easily deployed. In addition, PoE will accelerate the deployment of wireless access points and network cameras because power, which is rarely available above the ceiling, can now be offered over the Ethernet cable.
- **Reliability** - as a central UPS joins in, reliability rises towards the known "five nines". Moreover, the need for a local backup for each AC outlet is avoided.
- **Safety** - no mains voltages usage, only safe direct-current 48V levels.
- **Control** - SNMP management capabilities provide control and monitor of the PoE device and the powered devices.
- **Security** - shutting down unnecessary PDs when no one is at office ensures better business security.
- **Enhanced Applications** - as PoE becomes popular, equipping your application with PoE capabilities requires only a low per-port cost addition, enabling it to interoperate with a growing variety of devices.

Figure 1 illustrates a typical PoE installation. The PoE equipment resides in a communication room and connects to the Ethernet infrastructure via standard category 5 cabling.

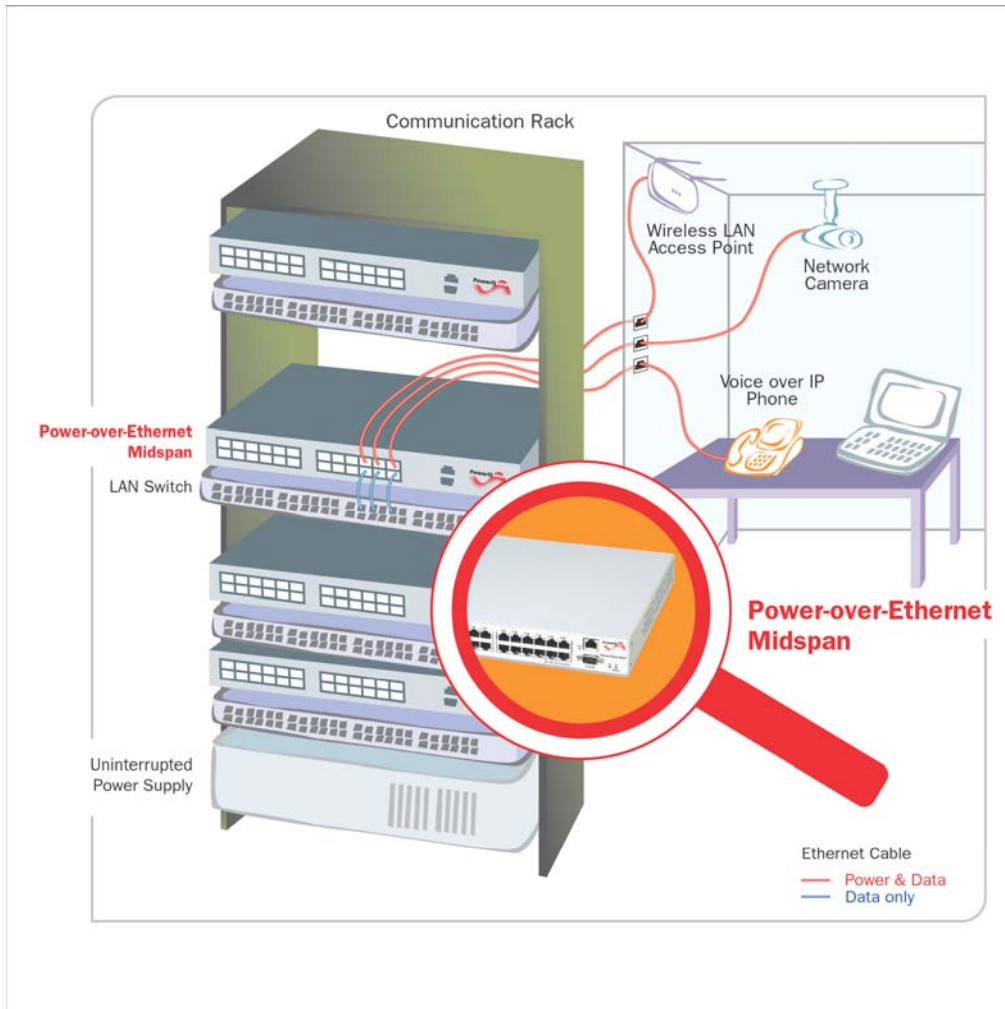

Figure 1 - Typical PoE installation

## Paper Goals

This white paper introduces PoE concepts, processes, considerations and designs from both the Sourcing side (Power Sourcing Equipment or PSE) and the Terminal side (Powered Device or PD) perspectives and details the current highlights of the IEEE 802.3af standard for provision of PoE.

---

## 2 PoE Technology

### Technological PoE Challenges

Implementation of a PoE solution involves numerous challenges. First and foremost, the solution must closely comply with communication and safety standards. The PSE is the side responsible for most technological aspects relates to safety.

#### *Safety*

- PSE must not damage existing cabling infrastructure nor non-powered devices connected to it. Therefore, power must only be provided when PoE-enabled terminals are detected and must be terminated quickly after their physical disconnection.
- PoE system must be protected from current overloads and short circuits scenarios.
- Thermal protection should be kept to avoid flammability.
- Protection of PSE's port from crossed-connection to an adjacent port.

#### *Data Integrity*

The introduction of DC power into an Ethernet network may increase noise susceptibility of the system and degrade the Ethernet signal. A PoE solution must not affect data communications, for any RJ-45 connectivity implemented over its cabled infrastructure. It should support 10/100-BaseT Ethernet connections and be upgradeable to support 1000-BaseT.

#### *Infrastructure Limitations*

When implementing a PoE system, numerous physical infrastructure limitations must be taken into consideration. CAT-5 cables commonly used in Ethernet infrastructure, for one, may carry voltage levels of no more than 80 Vdc, and RJ-45 connectors are rated at a maximum of 250 Volts and 1.5A, while safety standards rate voltages below 60 Vdc only as SELV (Safety Extra Low Voltage). Additionally, maximum channel resistance is rated at 20  $\Omega$ , including 100 meters of horizontal cables, patch cabling, connectors and connected hardware.

All of these considerations add up to a standard PoE voltage of 44-57 Vdc at 350-400 mA, with a minimum 15.4 watts power output at the PSE port.

#### *Isolation Requirements*

**Switch side** - According to Ethernet standard, 1500 Vac galvanic isolation is required between the main board circuitry of the switch, including protective and frame ground, and the Media Dependent Interface (MDI), which is the RJ-45.

IEEE 802.3af standard extends this requirement so the PoE unit resides in the switch should be isolated from the switch's main circuits. This implies to isolated power supplies and opto-coupled communication between the switch and the PoE circuitries, as may be seen in many applications.

**Terminal side (DTE)** - The IEEE 802.3af standard calls for 1500 VAC galvanic isolation between the link, the chassis ground and the DTE circuits. Since in many systems the power supply's return is tied to the chassis ground, for enhanced EMI reduction, a conflict may occur.

The required Isolation may be achieved using the following two methods:

- Power that is fed over Ethernet is isolated from DTE circuits by an isolated DC/DC converter that withstands 1500 VRMS.
- The terminal is housed in a non-conductive casing, with no external connections other than the RJ-45 data and power connector, resulting in the internal power supply input-output no longer needing to be electrically isolated.

### IEEE 802.3af Standard Status

The IEEE began the standardization process in 1999 driven by leading companies as 3Com, Intel, Nortel, Cisco and PowerDsine. They have recognized the need to supply power over Ethernet cables, but lack of a standard was a serious constrain. On June 2003, the standard was ratified.

802.3af-compatible Ethernet switches, midspans and terminals are currently offered by leading network equipment vendors, including 3Com, Alcatel, Avaya, Cisco, Fujitsu, HP, NEC, Nortel, PowerDsine, Proxim and many others. Many IP phone sets, Wireless LAN access points and other IP DTEs are now designed to receive operating power through Ethernet interfaces.

### MDI Settings

The Medium-Dependant Interface (MDI or RJ-45) serves as the data/power interface between Ethernet elements. As such, it has two optional connection methods, to carry the power, named Alternative A & B. Table 1 details the two power feeding alternatives.

Pin	Alternative A	Alternative B
1	Vport Negative	
2	Vport Negative	
3	Vport Positive	
4		Vport Positive
5		Vport Positive
6	Vport Positive	
7		Vport Negative
8		Vport Negative

Table 1 - RJ-45 PoE Pinout

### Alternative A

Power is carried over the data pairs (1/2 & 3/6) using the "Phantom Feeding" method, described in Figure 3, which illustrates one pair only.



Delivering power through an RJ-45 connector's center tap ("Phantom Feeding") guarantees that bi-directional data flow is maintained, regardless of a module's power status.

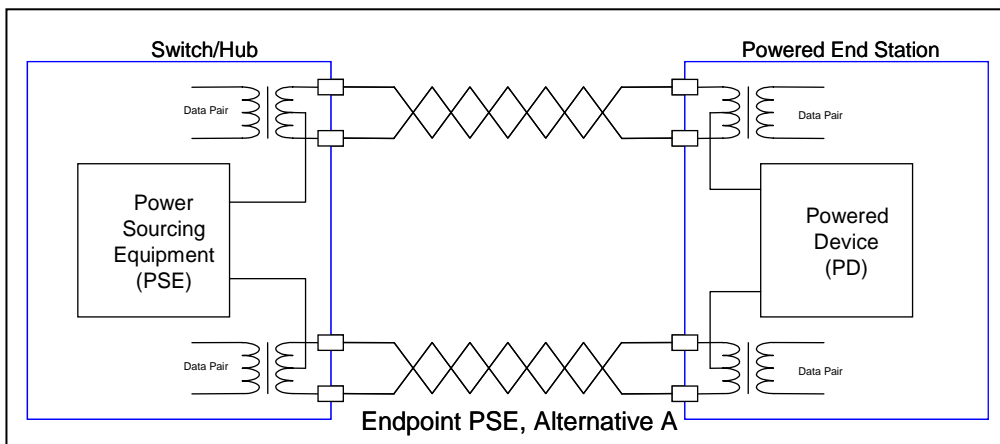

Figure 2 – PoE feeding using Alternative A (Data/Signal pairs)



**Alternative B**

Power is carried over the spare pairs (4/5 & 7/8). Each pair's wires are shorted to one another (Figure 4).

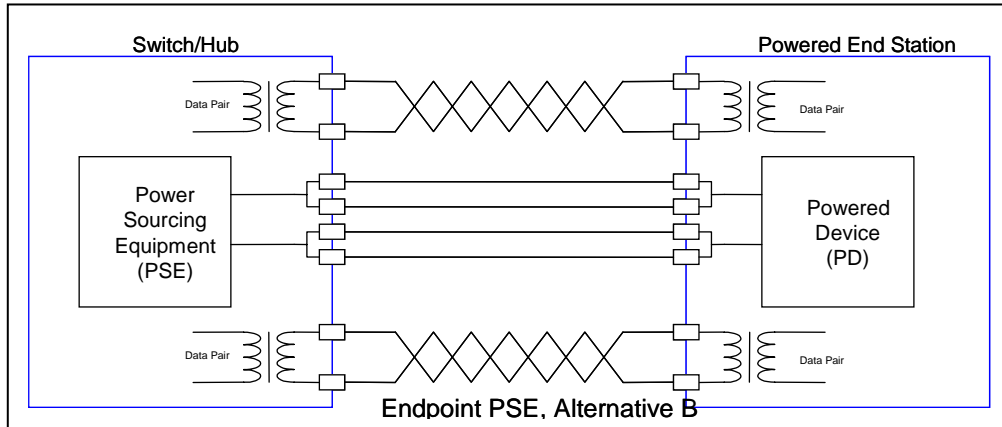

Figure 3 – PoE feeding using Alternative B (Spare pairs)

## PoE System Architecture

A typical PoE system consists of a PSE and a PD. The PSE may either be an Endspan (L2 Ethernet switch supporting PoE) or a Midspan (PoE hub). The PD is a PoE-enabled terminal such as an IP phone, Wireless LAN access point, etc.

A PoE system is deployed in a "star topology", so each PD is connected to a separate channel of the central PSE.

Power is delivered either over data pairs (Alternative A) or spare pairs (Alternative B) of standard CAT-5 cabling.

Figure 5 presents the common PoE system elements, their basic electrical design, and the connections that deliver power from the PSE and the PD.

### What are PSE and PD?

The IEEE 802.3af specification defines PSE as the element responsible for inserting power onto a Ethernet cable. The PSE may be located at the switch (Endspan configuration), or it may be a separate device located between the switch and the PD (Midspan configuration).

The PD is the natural termination of this link, receiving the power, and could be an IP phone, a WLAN access point or any other IP device requires power.

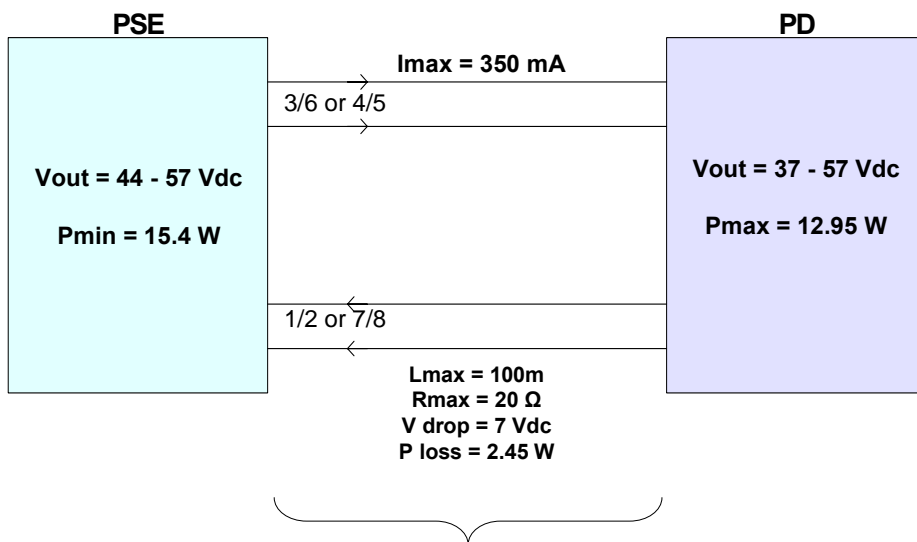

Figure 4 – PSE and PD interconnection

The standard defines some electrical parameters to be kept in PoE design:

- Operating voltage is normally 48 Vdc, but it may vary between 44 to 57 Vdc. In any case it should always be under the maximal SELV requirement of 60Vdc.
- Maximal current generated by the PSE is to vary between 350 to 400 mA. This level protects the Ethernet cables from over heating due to their parasitic resistance.
- The above values result in minimum of 15.4 watts in the PSE's port output. After cable loss, caused by parasitic resistance of about  $20 \Omega$  for a pair, the maximal power a PD can count on is 12.95 watts.

## Basic PSE

The PSE is kind of a power switch (Figure 6), controlling the PoE process described hereafter. As such, it holds the PoE "intelligence", therefore a CPU is required to control the PoE process while other analog components are doing the switching, sensing and power filtering activities.

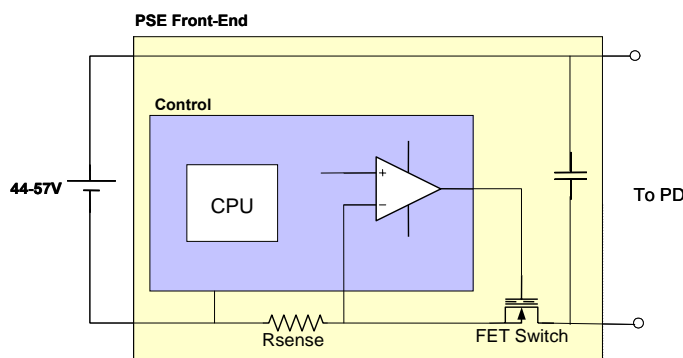

Figure 5 – Basic PSE Front-End (single port)

## Endspan and Midspan

There are two basic types of PSE: Endspan and Midspan. Endspan PSE integrates PoE into Ethernet switches, while Midspan PSE is an element resides between the switch and the terminal, providing power only.

Endspans are mainly for green-field installations thus what many vendors are starting to sell. Midspan devices, on the other hand, are for organizations looking to upgrade a network without replacing existing switches.

The **Endspan** is a switch that integrates the PoE source, to simplify the infrastructure, using "Phantom Feeding" on the center tap of the Ethernet pulse transformer (Figure 7). 802.3af allows the Endspan to use the spare pairs for power delivery instead of the data pairs, though the latter configuration is more commonly used.

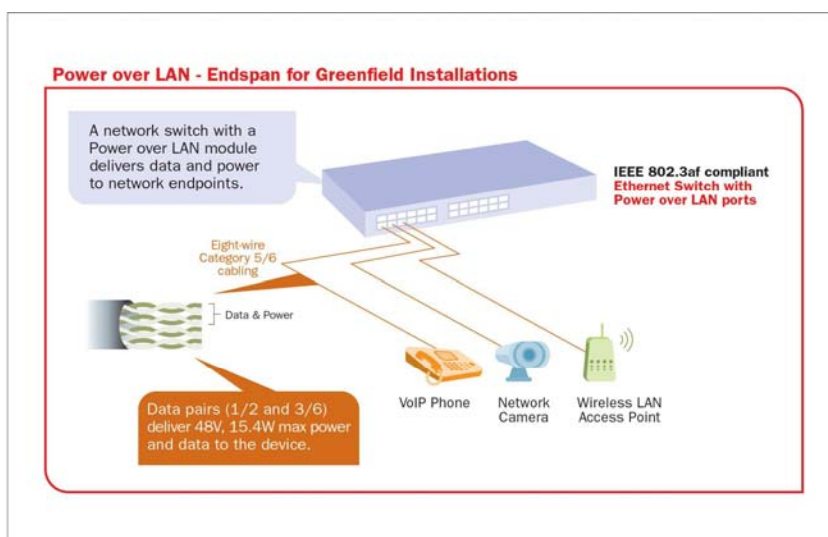

Figure 6 - Endspan PSE configuration

The **Midspan** is a patch panel like device that receives data lines from the switch and inserts power over the spare pairs, providing data and power out to the PD (Figure 8).

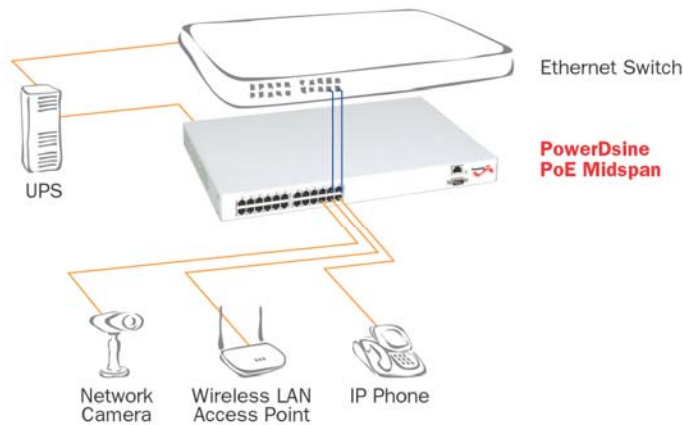

Figure 7 – Midspan PSE configuration

## Basic PD

802.3af defines a PD as a device that is either drawing power or requesting power from a PSE. The PD can be one of many different devices, including IP phone, wireless LAN access point, security network camera and other Ethernet terminals.

Figure 9 shows a simplified block diagram of a PD's electrical interface. Power can enter the PD with either polarity on data pairs (1/2 and 3/6) or on spare pairs (4/5 and 7/8). The data interface is a standard line transformer, with center tap on the primary that faces the RJ-45 jack. Data flows through the transformers to Ethernet PHY. The 48 Vdc power is extracted from the center taps and passes through a PoE interface block that acts as an intelligent switch.

In order to comply with the standard requirements, a device of a resistive nature must be positioned across the supply line, as detection is performed on the same path on which power is provided. The standard requires the use of a rectifier bridge, and IEEE-compliant power sources should be able to detect a resistor even when a diode bridge exists in the path.

- **Diode Bridges:** the standard requires the use of two diode bridges placed upon the data and spare entrances. The PD must be able to accept power from either data or spare pairs and it should be insensitive to the power's polarity.
- **Signature:** presents a resistor with standard-defined value (25 K $\Omega$ ). The PSE utilizes it by inducing low probing voltages, to discover the presence of such a resistor. This low energy is completely harmless to pre-standard equipment, allowing the PSE to verify the existence of a valid PD. Should the PSE identify anything other than a valid PD, it will not inject power to the line.
- **Classification:** this block reacts to the PSE's classification probing with a proper current value, defining the power class of the PD.
- **Isolation:** FET switch is responsible for letting the PSE power go through the application only after detection and classification processes have successfully ended.
- **DC/DC:** Following the PoE interface is a DC/DC converter block, converting the 36 to 57 Vdc input to the application's operational voltage.

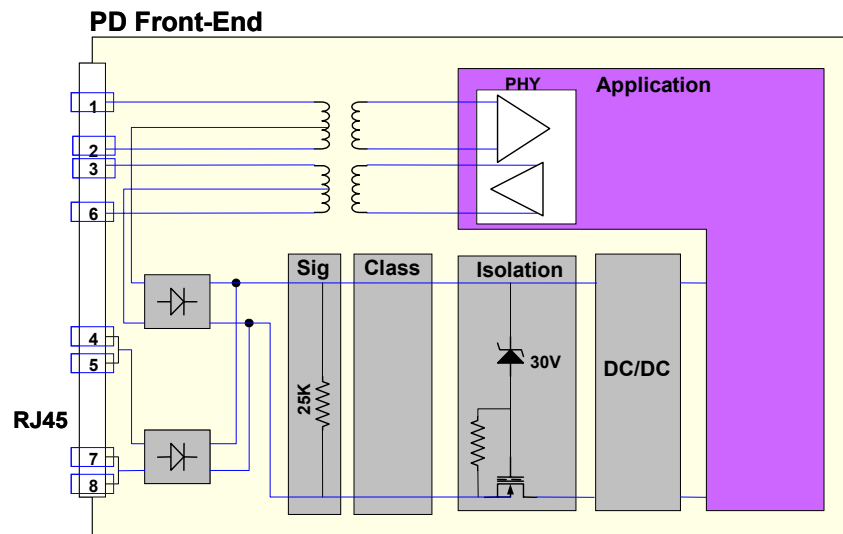

Figure 8 – Basic PD Front-End

Table 2 summarizes circuit parameters as per IEEE 802.3af-2003 requirements and lists all of the electrical parameters a PD designer needs to be aware of.

Parameter	Min	Max	Unit
Signature Resistance	23.75	26.25	K $\Omega$
Startup Time (till I>10mA)		300	ms
Power Consumption		12.95	W
Operating Input Voltage Range	36	57	V
Must Turn on Voltage		44	V
Must Turn off Voltage	30		V
Input Current (@36Vdc)	10	350	mA
Input Current, Peak		400	mA

Table 2 - 802.3af basic requirements from PD

### 3 The PoE Provision Process

While adding PoE support to networked devices is relatively painless, it should be realized that power cannot simply be transferred over existing CAT-5 cables. Without proper preparation, doing so may result in damage to devices that are not designed to support provision of power over their network interfaces.

Figure 10 below illustrates the basic necessary elements required during the PoE power provisioning cycle. The PSE is the manager of the PoE process. In the beginning, only small voltage level is induced on the port's output, till a valid PD is detected during the Detection period (1). The PSE may choose to perform classification (2), to estimate the amount of power to be consumed by this PD. After a time-controlled start-up (3), the PSE begins supplying the 48 Vdc level to the PD (4), till it is physically or electrically disconnected (5). Upon disconnection, voltage and power shut down. Right afterwards, the cycle is restarted (1).

Several incidents as consumption overload, short circuit, out-of-power-budget and other scenarios, may terminate the process in the middle, only to restart it from phase (1) again.

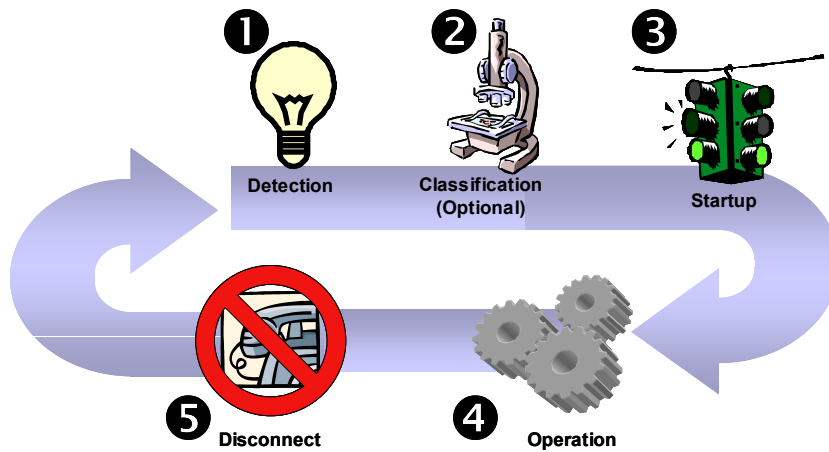

Figure 9 - PoE process cycle

Since the PSE is responsible for the PoE process timing, it is the one generating the probing signals prior to operating the PD and monitoring the various scenarios that may occur during operation.

All probing is done using voltage induction and current measurement in return. Figure 11 presents the voltage signal induced by the PSE during the PoE process.

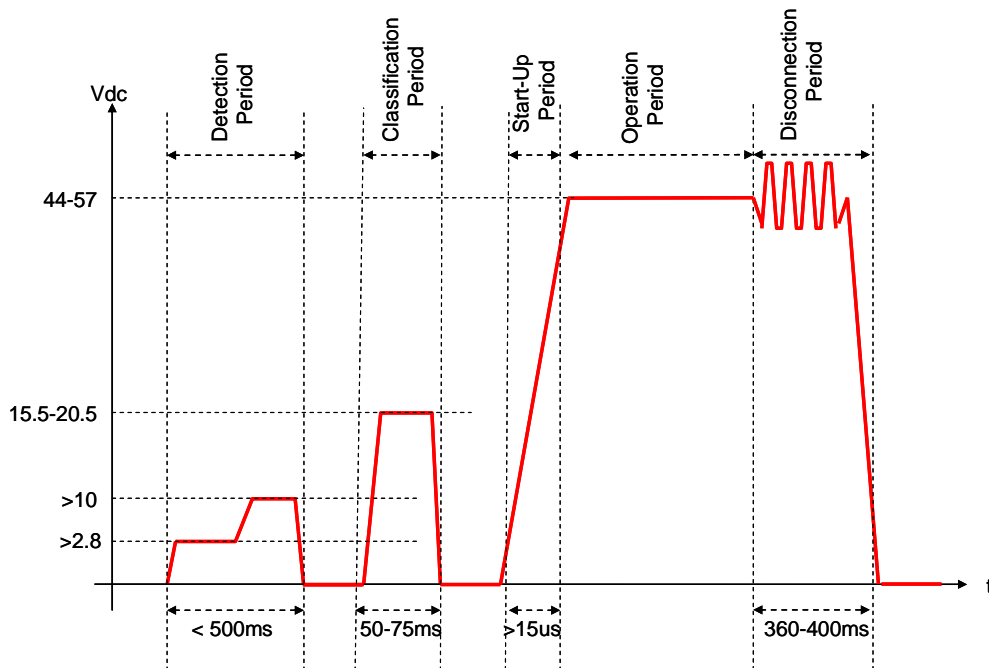

Figure 10 – PSE's signal during PoE process

### Line Detection

Before power is applied, safety dictates that it must first be ensured that a valid PD is connected to the PSE's output. This process is referred to as "line detection", and involves the PSE seeking a specific, 25 KΩ signature resistor. Detection of this signature indicates that a valid PD is connected, and that provision of power to the device may commence.

The signature resistor lies in the PD's PoE front-end, isolated from the rest of the the PD's circuitries till detection is certified. The signature has a tolerance range seen in Figure 12.

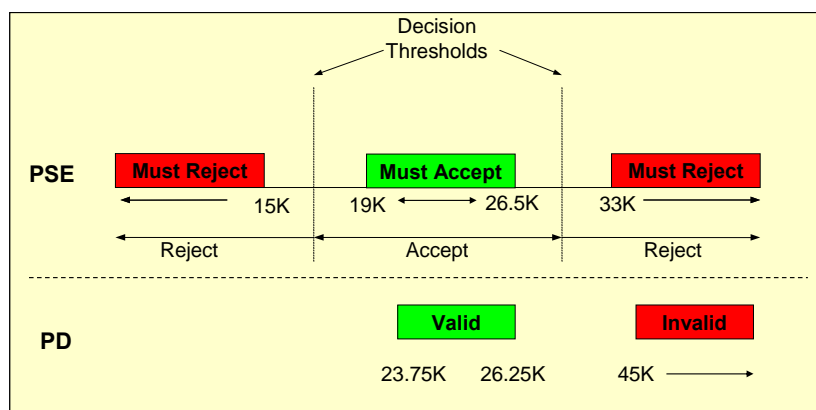

Figure 11 – Resistive signature thresholds

### Classification

Once a PD is detected, the PSE may optionally perform classification, to determine the maximal power a PD is to consume. The PSE induces 15.5-20.5 Vdc, limited to 100 mA, for a period of 10 to 75 ms responded by a certain current consumption by the PD, indicating its power class.

The PD is assigned to one of 5 classes: 0 (default class) indicates that full 15.4 watts should be provided, 1-3 indicate various required power levels and 4 is reserved for future use. PDs that do not support classification are assigned to class 0. Special care must be employed in the definition of class thresholds, as classification may be affected by cable losses.

Class	PD Current - Classification Period [mA]	PD Power - Operation Period [W]	Note
0	0 - 4	0.44 -12.95	Default
1	9 - 12	0.44 -3.84	Optional
2	17 - 20	3.84 -6.49	Optional
3	26 - 30	6.49 -12.95	Optional
4	36 - 44	Future use	Future use

Table 3 - PD Classification values

Classifying a PD according to its power consumption may assist a PoE system in optimizing its power distribution. Such a system typically suffers from lack of power resources, so that efficient power management based on classification results may reduce total system costs.

### Start-up

Once line detection and optional classification stages are completed, the PSE must switch from low voltage to its full voltage capacity (44-57 Volts) over a minimal amount of time (above 15 microseconds). A gradual startup is required, as a sudden rise in voltage (reaching high frequencies) would introduce noise on the data lines.

Once provision of power is initiated, it is common for inrush current to be experienced at the PSE port, due to the PD's input capacitance. A PD must be designed to cease inrush current consumption (of over 350 mA) within 50 ms of power provision startup, as seen in Figure 13

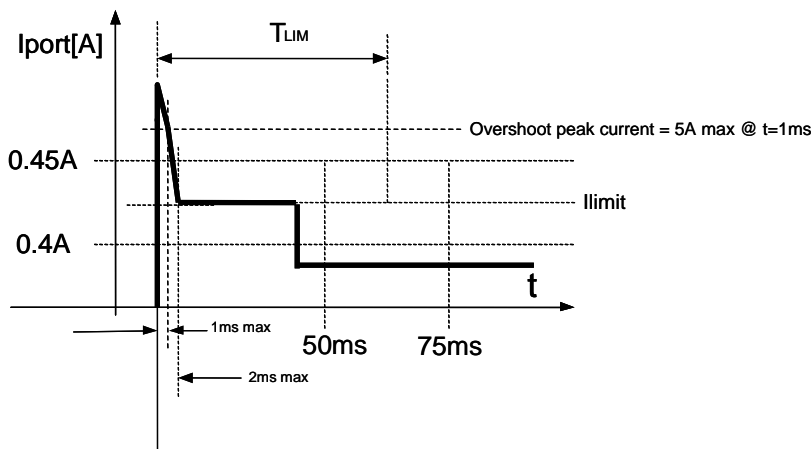

Figure 12 - PoE Provision Startup



## Operation

During normal operation, the PSE provides 44-57 Vdc, able to support a minimum of 15.4 watts power.

As shown in Figure 14, a PSE design contains definitions for  $I_{cut}$ ,  $I_{lim}$  and  $I_{min}$  values (these may be customized).  $I_{cut}$  represents a level beyond which power consumption is regarded as an overload (this value may range from 350 to 400 mA).  $I_{lim}$  represents the highest consumption level possible (this value may range from 400 to 450 mA).  $I_{min}$  is the minimal consumption level permitted (it may range from 5 to 10 mA).

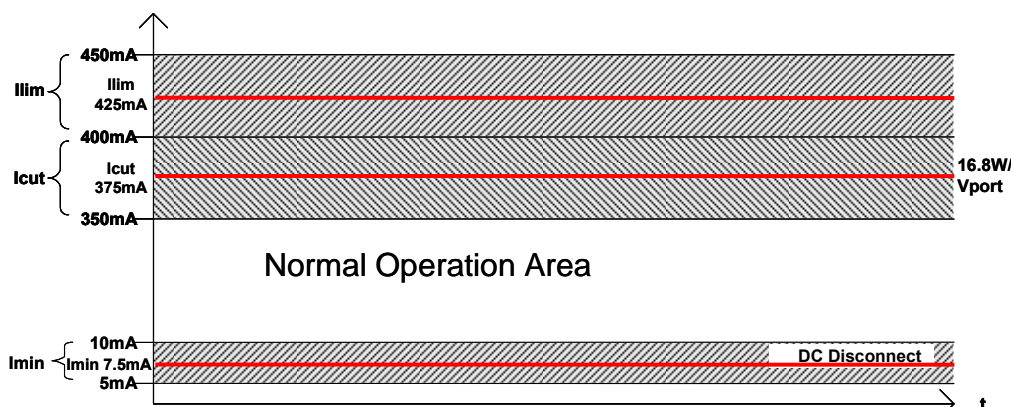

Figure 13 - Normal Operation

## Power Overloads

The IEEE 802.3af standard defines handling of overload conditions. In the event of an overload (a PD drawing a higher power level than the allowed 12.95 Watts), or an outright short circuit caused by a failure in cabling or in the PD, the PSE must shut down power within 50 to 75 milliseconds, while limiting current drain during this period to protect the cabling infrastructure. Immediate voltage drop is avoided to prevent shutdown due to random fluctuations.

As shown in Figure 15, consumption may never exceed  $I_{limit}$ . Should consumption exceed  $I_{cut}$  for a period longer than  $T_{cut}$ , power to the overloaded port will be disconnected completely, and stays off for a "penalty" period (3 to 5 seconds).

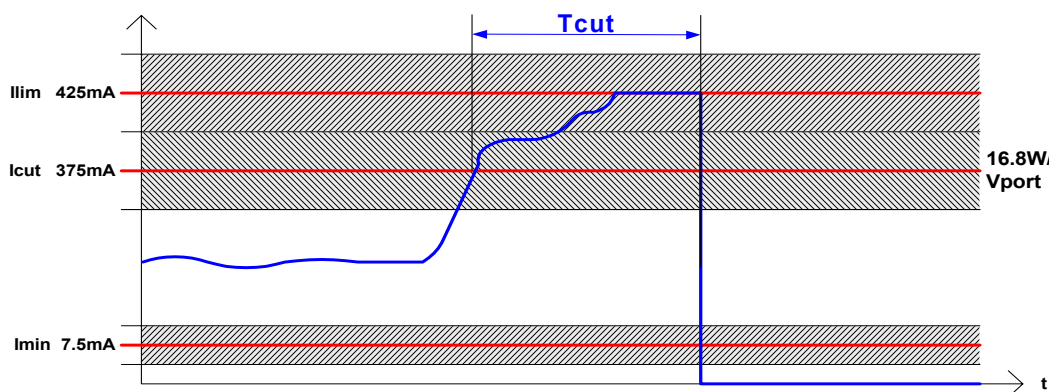

Figure 14 - Power Overload Handling ( $T_{cut} = 50$  to  $75$  ms)

## Power Disconnection Scenarios

The IEEE 802.3af standard requires that devices powered over Ethernet be disconnected safely (i.e. power needs to be shut down within a short period of time following disconnection of a PD from an active port).

When a PD is disconnected, there is a danger that it will be replaced by a non-PoE-ready device while power is still on. Imagine disconnecting a powered IP phone utilizing 48 Vdc, then inadvertently plugging the powered Ethernet cable into a non-PoE notebook computer. What's sure to follow is not a pretty picture.

The standard defines two means of disconnection, DC Disconnect and AC Disconnect, both of which provide the same functionality - the PSE shuts down power to a disconnected port within 300 to 400ms. The upper boundary is a physical human limit for disconnecting one PD and reconnecting another.

### DC Disconnect

DC Disconnect detection involves measurement of current. Naturally, a disconnected PD stops consuming current, which can be inspected by the PSE. The PSE must therefore disconnect power within 300 to 400 ms from the current flow stop (Figure 16). The lower time boundary is important to prevent shutdown due to random fluctuations.

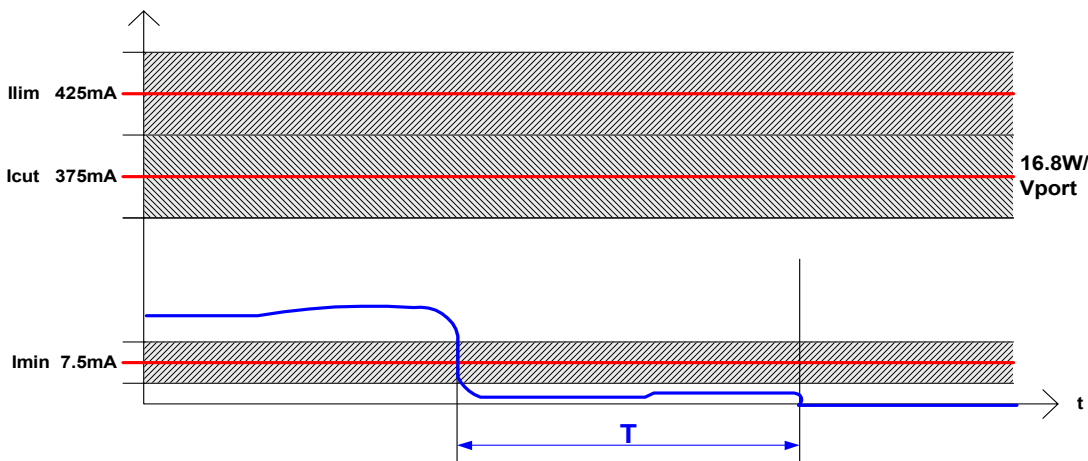

Figure 15 - Power Disconnect Timeout ( $T = 300$  to  $400$  ms)

Figure 17 illustrates DC modulation that may also be implemented, allowing a PD to draw a minimum current so as not to be identified as disconnected. With DC modulation implemented, the PD can consume no current (and no power) for about 80% of the time and still remain powered.

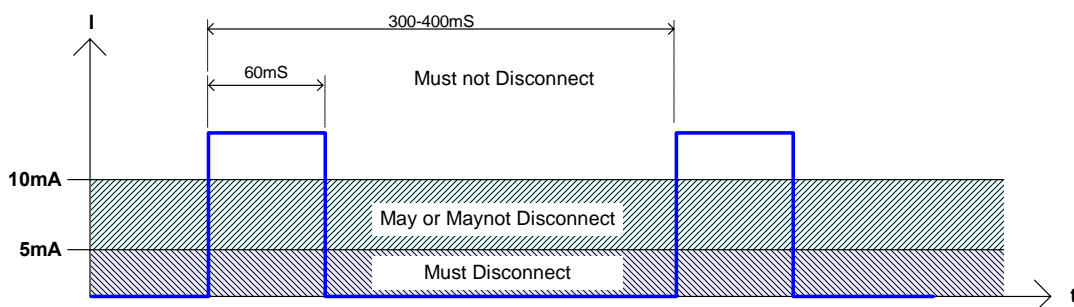

Figure 16 - DC Modulation



DC Modulation needs to be supported by both the PSE and the PD.

### AC Disconnect

This method is based on the fact that when a valid PD is connected to a port, the AC impedance measured on its terminals is significantly lower than in the case of an open port (disconnected PD).

AC Disconnect detection involves the induction of low AC signal in addition to the 48 Vdc operating voltage. The returned AC signal amplitude is monitored by the PSE at the port terminals. During normal operation, the PD's relatively low impedance lowers the returned AC signal while a sudden disconnection of this PD will cause a surge to the full AC signal level and will indicate PD disconnection.

The PSE maintains or removes port power depending on the impedance levels (see Figure 18). Should AC impedance be lower than 27 K $\Omega$ , power must be maintained. If the impedance ranges from 27 K $\Omega$  to 2,000 K $\Omega$ , power may either be maintained or removed. If impedance exceeds 2,000 K $\Omega$ , power must be removed.

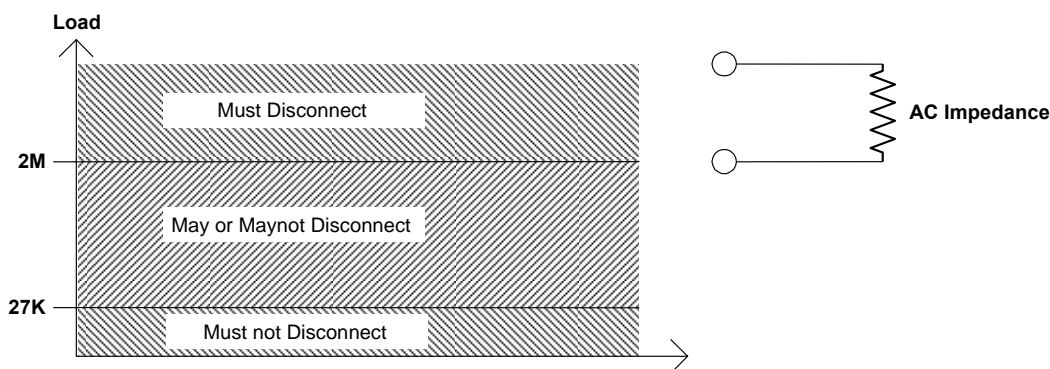

Figure 17 - AC Disconnect Levels



Disconnect identification and handling is performed solely by the PSE, and requires no special handling by the PD.

### Power Management

A 24-port system designed for full 15.4 Watt power provision requires 370 watts (!) and introduces numerous thermal challenges. Common PoE scenarios are typically less demanding. For example, the total power consumption of an application involving 20 IP phones (typically 4-5 watts), 2 Wireless LAN access points (8-10 watts) and 2 network cameras (10-13 watts) per switch will be 146 Watts. A 150 or 200 watt power supply should enable a power sourcing switch to easily face this challenge, drastically reducing system's cost. Under some conditions, the total output power required by PDs may exceed the maximum available power provided by the PSU (Power Supply Unit). In order to keep the majority of ports active, within available power limits, a power management system needs to be implemented, to control the output power delivered to each port.

Ports exceeding power consumption thresholds are deactivated (and tagged) according to predefined priorities, until aggregate power consumption has been sufficiently reduced. Power budget should be managed according to customer configured or factory preset parameters, including maximum available power, port priority and maximum allowable power per port. However, usage can be made of the classification values of each PD.



Power management is handled entirely within the PSE and power allocation may be based on the results of the classification process.

## 4 PoE Solutions

### Midspan Solutions

PowerDsine's 6000 series (1, 6, 12 and 24 ports solutions) and PowerDsine 3006 (6-port solution) are PoE hubs compliant with the IEEE 802.3af standard. They provide power over standard CAT-5 twisted pair cables, effectively eliminating the need for bulky AC adapters and enhancing the operating reliability of Ethernet devices as IP telephones, WLAN access points, Security network cameras and other IP terminals.



Figure 18 – PowerDsine's 6000 series of PoE Hubs



Figure 19 - PowerDsine's 3000 series of PoE Hubs

PowerDsine's Midspans may be deployed alongside an existing Ethernet or Fast Ethernet switch and connected to standard CAT-5 cabling infrastructure to enable PoE provision. This architecture enables customers to protect and maximize the usefulness of their investments in both cabling infrastructure and Ethernet switch equipment.

PowerDsine's Midspans offer end-users a cost-effective solution that simplifies installation of wireless LAN access points and network security camera systems. The PoE hub eliminates electrician costs incurred by installation of AC outlets near access points and cameras and ensures negligible, if any, disruption in operations during system installation.

Optional SNMP manager offers complete management capabilities for easy on-line supervision, configuration, monitoring and control of the power hubs along with Windows graphic user interface and web-browsed management capabilities.

### Integrated Solutions

PowerDsine's integrated solutions for Ethernet switch vendors range from PoE Power Manager ICs to integrated PoE Modules. These are tailored to meet the design challenges, as well as the cost, simplicity and time-to-market requirements of even the most demanding equipment manufacturers.

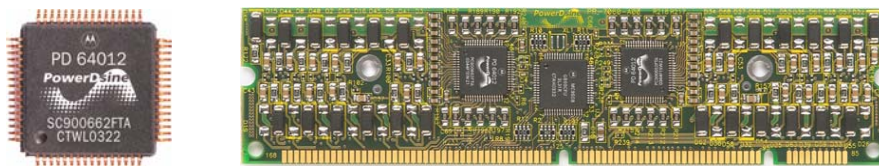

Figure 20 - PowerDsine's PD64012 PoE IC (left) and PD67000 PoE DIMM Module (right)

The PD64012 IC in

Figure 21 is the first result of collaboration between PowerDsine and Motorola. This product provides power to 12 Ethernet ports (with 15.4 W per port) and addresses the needs of 12, 24 and 48-channel output equipment. Also, it minimizes the number of external components required thus reduces overall system costs.

PD67000 PoE DIMMs family, based on PD64012 IC, supports 12 or 24 ports per DIMM, to implement a complete 48 ports solution with only two modules. PoE DIMMs give the switch vendor design modularity and field upgradeability at a small foot print.

### Compatible PDs

Currently, there are many 802.3af-compliant PDs available in the market, ranging from IP phones, to WLAN access point, Security networking camera, bluetooth access points, and many others.

Below is an example of some:



Figure 21 – Avaya AP-5 WLAN AP, Cisco 7970 IP Phone, Sony SNC-Z20N Net Camera

### About PowerDsine

PowerDsine is a leading vendor of PoE solutions. The company first developed PoE products in 1998 and has since assumed the major role in shaping the market.



A founding member of the IEEE 802.3af Task Force, PowerDsine serves as a continuous driving force in setting the standard for delivering power over common Ethernet cables.

PowerDsine offers its solutions to corporate users via the company's own PoE product line and through OEM agreements with leading communications equipment manufacturers in the datacom industry.

PowerDsine's product line comprises a variety of PoE Midspan devices, as well as integrated solutions embedded directly into Endspan (Ethernet switch).

For more information on PowerDsine and its state-of-the-art PoE products, please visit <http://www.powerdsine.com>.



---

**Copyright © 2004 PowerDsine Ltd. All rights reserved.**

This document contains information that is proprietary to PowerDsine. No part of this document may be reproduced or distributed in any form and by any means, or stored in a database or retrieval system, without the prior written approval of PowerDsine.

The information contained herein is believed to be accurate and reliable at the time of printing. However, PowerDsine Ltd. cannot be held responsible for inadvertent errors, inaccuracies, omissions or subsequent changes. In the interest of continuous product improvement, and in view of our commitment to enhancing quality and reliability, PowerDsine Ltd. reserves the right to make changes to its products and their specifications at any time.

The company is committed to maintaining full compliance with the IEEE 802.3af standard. It is suggested that before embarking on any product design based on the details presented in this document, the latest and most current information be obtained from PowerDsine.

---

**International Headquarters**

PowerDsine Ltd.  
1 Hanagar St.,  
P.O.Box 7220  
Hod Hasharon 45421  
Israel  
Tel: +972-9-7755100  
Fax: +972-9-7755111  
sales@powerdsine.com

**North America**

PowerDsine, Inc.  
1865 New Highway  
Farmingdale, NY 11735  
USA  
Tel: +1-631-756-4680  
Fax: +1-631-756-4691  
sales@powerdsineusa.com

**Europe**

PowerDsine UK  
Lakeside House  
1 Furzeground Way  
Stockley Park, Uxbridge  
UB11 1BD, United Kingdom  
Tel: +44 (0) 208 622 3107  
Fax: +44 (0) 208 622 3200  
uk@powerdsine.com

**[www.powerdsine.com](http://www.powerdsine.com)**